

FORMAX®

HERE BEGINS YOUR ULTIMATE VALUE

FPV Series
Proportional Valve

FPV-40



Please read the brochure carefully before operation.

■ Coding Principle

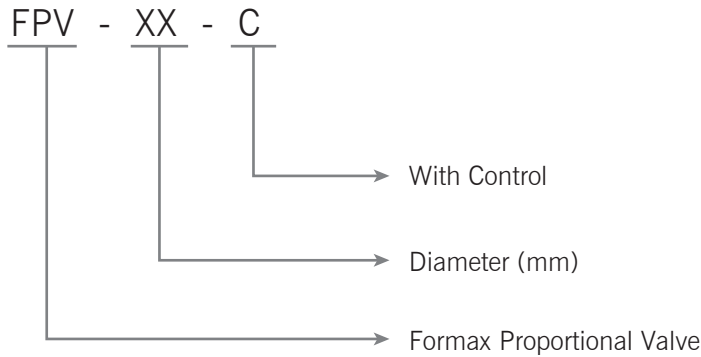

■ Features

Standard Configuration

- European shape, beautiful appearance, easy installation and simple operation
- Unique valve body design makes material transportation more smooth
- Solenoid valve performance is stable, cylinder movement is accurate, ensuring accurate mixing ratio
- No need to order control box when using with E-type European series vacuum loader
- Applicable to the immediate recycling of crushed materials, which can reduce the cost of expenditure
- 1-4 layers of working mode selection function to make the mixing more uniform

Options

- In other occasions, you can choose the control box to use

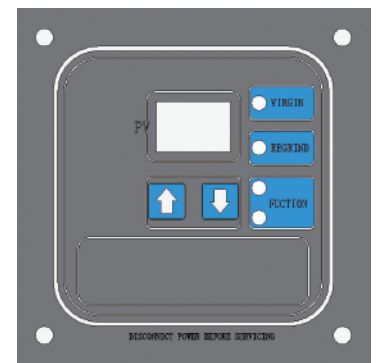

FPV-C Control Panel (Optional)

■ Application

- ① Material Tank
- ② Proportional Valve
- ③ E-Type Vacuum Loader
- ④ Granulator

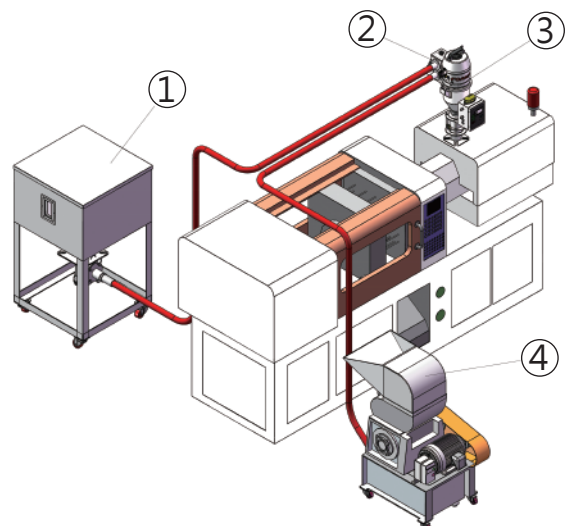

Working Principle

When the vacuum time and the secondary material ratio are set, the cylinder pushes the stopper 1, the stopper 2 closing and opening to control the proportion of raw materials and secondary materials for entering to the hopper loader, to achieve the purpose of proportional mixing

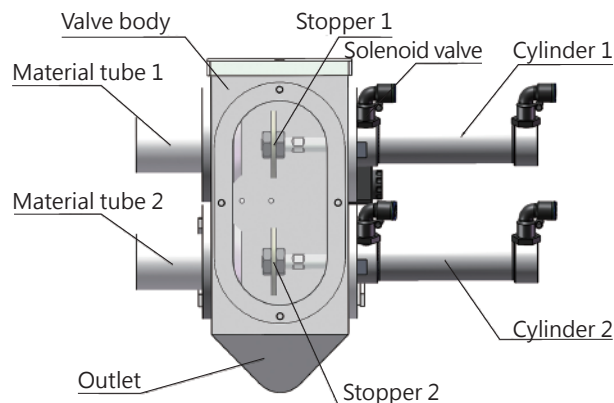

Outline Drawings

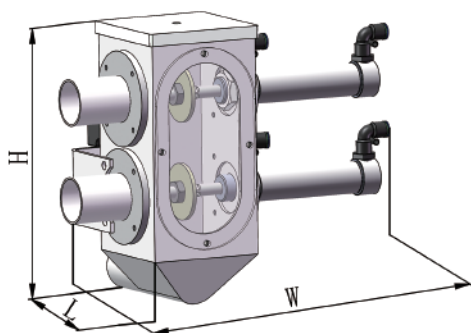

FPV

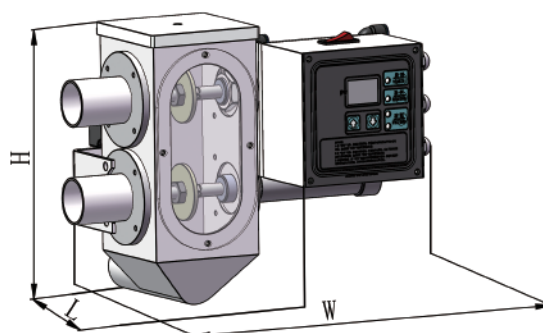

FPV-C (with Own Control)

Specifications

Model	Driving force	Drive mode	Maximum throughput	Material Tube (inch)	Outline Dimensions (mm) H×W×L	Net Weight(Kg)
FPV-40	3Kg/cm ² High pressure air	Cylinder	350Kg/hr	1.5	227×288.5×142	3.0
FPV-50	4Kg/cm ² High pressure air	Cylinder	550Kg/hr	2	227×288.5×142	3.0
FPV-65	5Kg/cm ² High pressure air	Cylinder	700 Kg/hr	2.5	227×288.5×142	3.0

Note: 1) With E/S+M vacuum loader including FPV Control, need option, add "C" after Model
 2) All output capacities of above models are based on data from bulk density 0.65kg/L, dia. 3~5mm master batch in a test criteria of continuous running.
 3) Voltage: 1φ, 230VAC, 50Hz

Specifications are subject to change without prior notice.



China
Formax Automation, Inc.

Dongguan
 Xianxi New Industrial Zone, Xianxi Community,
 Changan Town, Dongguan, Guangdong, China
 Tel. +86-769-3899-9898 Fax. +86-769-8533-3467

Kushan
 No.138-20, Hengshan Road, Kunshan, Jiangsu, China
 Tel. +86-512-5700-8308 Fax. +86-512-5700-8306

Taiwan
Formax Equipment Inc.

7F-1, No.265, NanKang Road, Luchu Dist.,
 Taoyuan City, Taiwan
 Tel. +886-3-2121-725 Fax. +886-3-2127-960

www.formax88.com
www.formaxpa.com



All rights reserved.